

# 1502 4:3 PCAP

## Desktop Touch Monitor



## Features

- + Flat appearance design
- + ABS+PC plastic shell material
- + Front frame against dust and liquids
- + Hidden cooling air duct structure
- + Industrial grade LCD, LED backlight
- + Resolution 1024 X768@60Hz
- + High contrast and high brightness
- + 10 point projective capacitive touch screen
- + Cover plate anti riot and anti fingerprint
- + Video interface: HDMI+VGA
- + Stable base with adjustable angle
- + Back VESA wall mounting hole
- + Support OS: Windows/Android/Linux
- + 2-year warranty



## Optional:

- No Touch
- Private Filter
- Touch interface: RS232
- Video interface: Display Port
- All-in-one (Windows/Android )

## TDS1502 Desktop Touch Monitor Specifications

Model	1502
Diagonal	15"
Color	Black/Gray
Aspect Ratio	4:3
Active Area	304.12X228.09(mm)
Dimensions	346X270X60(mm)
Resolution	1024 X768@60Hz
Viewing Angle	Horizontal: 85°/85°, Vertical: 85° /85°
Number of Colors	16.2 M
Brightness (typical)	LCD Panel: 350 nits, PCAP: 315 nits
Contrast Ratio	1500:1
Response Time	15ms
Touch Technology	PCAP(Projected Capacitive) - 10 points
Input method	Finger, Capacitance pen(Standard) Gloves touch (Thickness≤2mm))
Transmittance	≥90%
Touch Interface	USB 2.0
Video Interface	VGA+HDMI
Speaker	TwoX2W internal speakers
Input Voltage	AC:100-240VAC, 50/60Hz
Sealability	Seal between touchscreen and frame
Drop Test	The 450 g ball does not broken when it falls from 1.0 meters
Weight (Unpackage)	4.2KG
Shipping Dimensions	520X340X135(mm)
Temperature	Operating: 0°C-40°C; Storage :-20°C-60°C
Humidity	Operating: 20% to 70%; Storage: 10% to 80%
MTBF	50,000 hours demonstrated
Mounting Options	VESA:75X75(mm) 100X100 (mm)
BASE	Adjusting angle: 0°C-90°C(Optional)
Power Supply	DC:12V/3A
Warranty	2-year
Agency Approvals	FCC; CE; RoHS
Support OS	Windows/ Android/Linux
What's in the Box	1*USB cable, 1*VGA cable, 1*DC cable

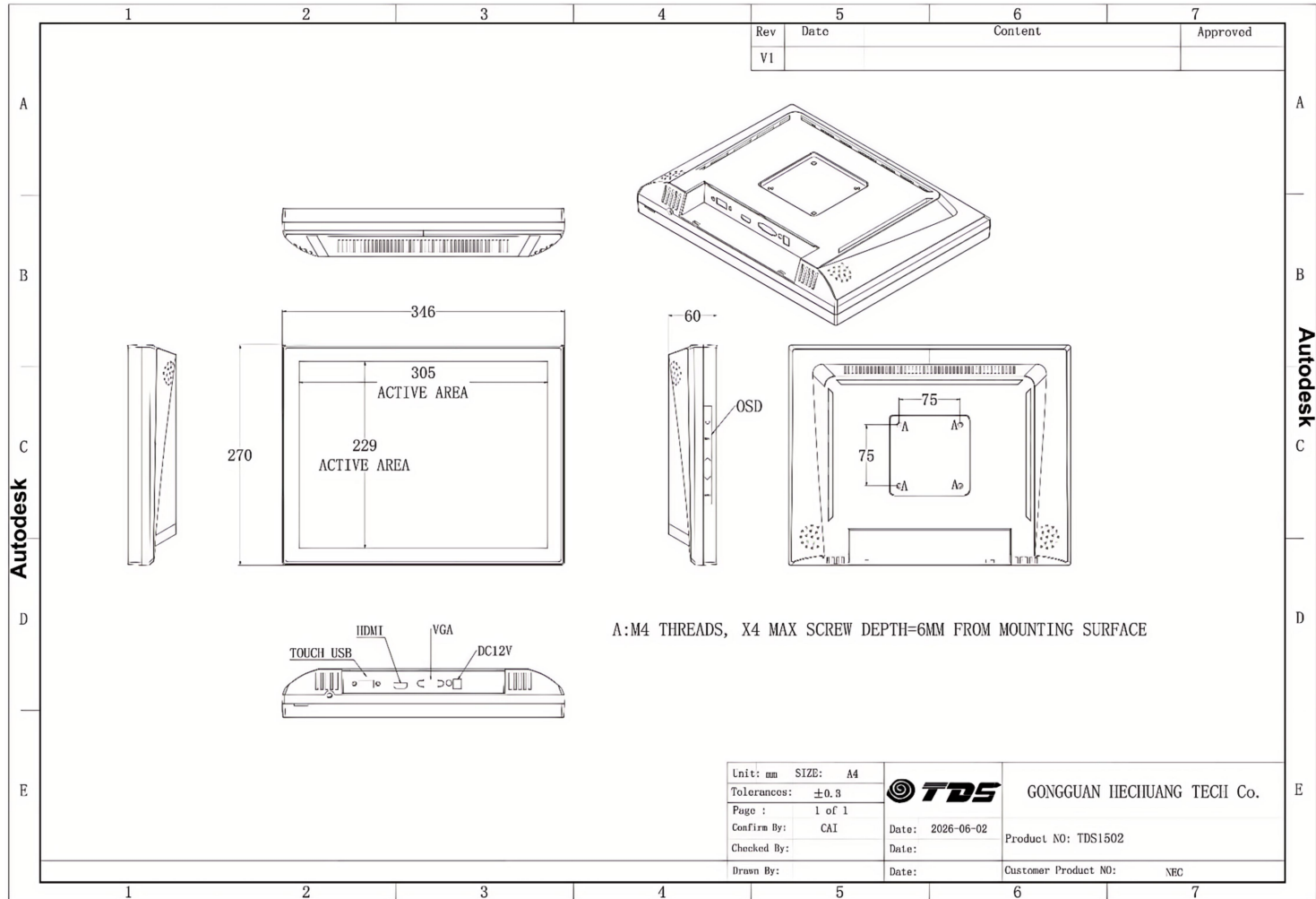

5		6		7	
Rev	Date	Content		Approved	
V1					

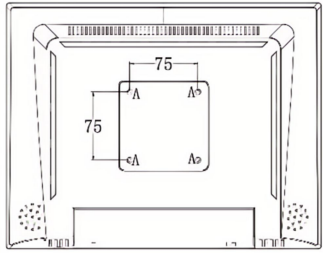
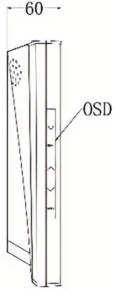
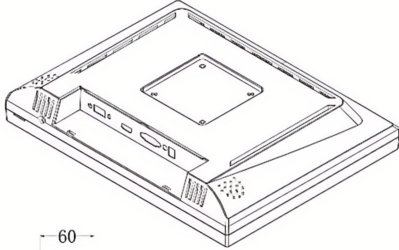
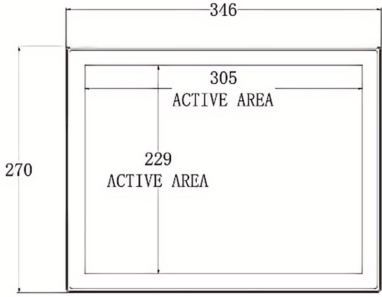

A:M4 THREADS, X4 MAX SCREW DEPTH=6MM FROM MOUNTING SURFACE

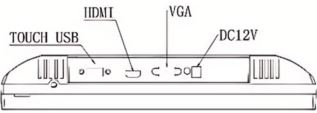

Unit: mm	SIZE: A4		GONGGUAN HECHUANG TECH Co.
Tolerances: ±0.3	Page: 1 of 1		Product NO: TDS1502
Confirm By: CAI	Date: 2026-06-02	Date:	Customer Product NO: NEC
Checked By:	Date:	Date:	
Drawn By:	Date:	Date:	